



## MXT® Hydraulic Torque Wrench

The MXT is the world's best-selling industrial bolting system with over one hundred thousand in use around the world. Since 1990, the signature blue housing has represented quality, durability, and reliability on job sites in every major industry. From the tallest roller coasters to the world's largest bridges, the MXT has the power to get the job done.

### LOCK-UP RELEASE



The MXT was the first tool in the industry to feature a release lever that allows you to release the tool if it locks on the application. (Also found on the AVANTI).

### NO-SLIP RATCHET



The MXT pioneered this new system for more powerful breakout and faster tightening. The secondary pawl inside the tool prevents the ratchet from turning opposite of the direction it is being driven.

### SPECIAL ALLOY OPTION



The MXT-SA provides the proven reliability of the MXT design with advanced materials used to increase lifespan further for extreme usage. The MXT-SA tools come with a 5-year, no-questions-asked warranty.



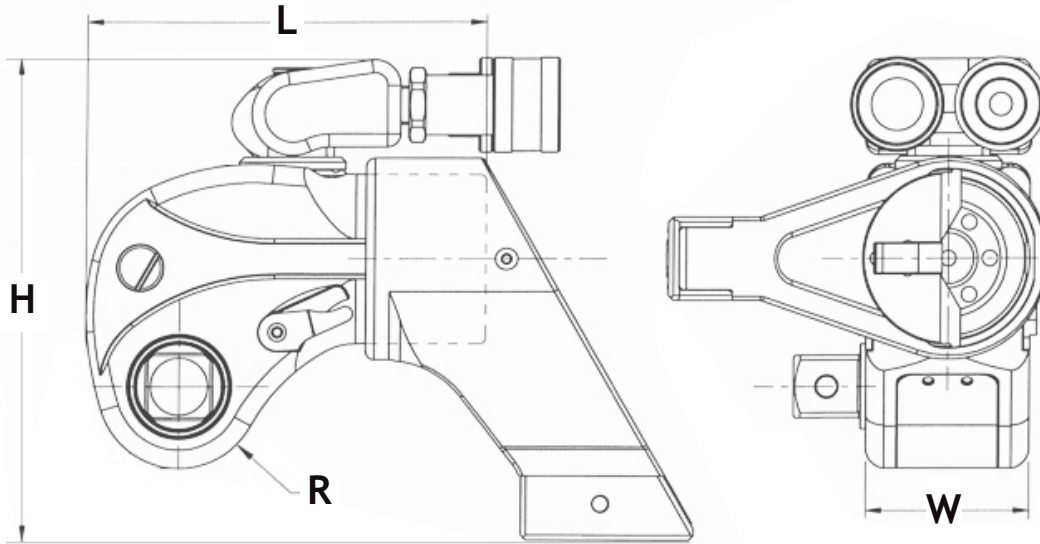

LEGEND: H = HEIGHT W = WIDTH L = LENGTH R = RADIUS

MODEL NUMBER	H	W	L	R	SQUARE DRIVE	WEIGHT	TORQUE	
<b>IMPERIAL</b>	in.					lbs.	ft-lbs (Min)	ft-lbs (Max)
MXT - .7	4.25	1.62	3.96	0.81	3/4	2.69	118	822
MXT - 1	4.90	1.97	4.88	0.98	3/4	3.95	200	1,340
MXT - 3	6.12	2.63	6.34	1.31	1	8.29	480	3,230
MXT - 5	7.22	3.16	7.61	1.57	1-1/2	14.20	835	5,590
MXT - 10	8.80	3.95	9.51	1.96	1-1/2	24.80	1,755	11,520
MXT - 15	9.67	4.38	10.55	2.18	2-1/2	36.00	2,268	15,399
MXT - 20	10.24	4.73	11.41	2.36	2-1/2	43.40	2,960	19,760
MXT - 35	12.42	5.82	14.03	2.90	2-1/2	77.45	5,400	37,100
<b>METRIC</b>	mm				in.	kg	Nm (Min)	Nm (Max)
MXT - .7	108	41	101	21	3/4	1.22	160	1114
MXT - 1	124	50	124	25	3/4	1.80	271	1816
MXT - 3	155	67	161	33	1	3.77	650	4377
MXT - 5	183	80	193	40	1-1/2	6.45	1131	7575
MXT - 10	224	100	242	50	1-1/2	11.27	2378	15610
MXT - 15	246	111	268	55	2-1/2	16.36	3073	20866
MXT - 20	260	120	290	60	2-1/2	19.73	4011	26775
MXT - 35	315	148	356	74	2-1/2	35.20	7317	50271

## The World's Most Trusted Industrial Bolting Systems

HYTORC owns all content, copyrights, trademarks and patents in this document. © 2021 HYTORC. Any unauthorized use or distribution of any material from this document is strictly prohibited.



**TOOL SOLUTIONS**  
Hidráulico - Eléctrico - Neumático

**Address:**

PH Ofidepositos Tocumen, Bodega  
#10 Via Panamericana, Mañanitas.  
Ciudad de Panamá, Panamá

**Phone:**

507 382-8015

**Email:**

[info@toolsolutionscorp.com](mailto:info@toolsolutionscorp.com)

**Online:**

[toolsolutionscorp.com](http://toolsolutionscorp.com)