



LITHIUM SERIES®II Electric Torque Tool

The LITHIUM SERIES II Electric Torque Tool is the next revolution in bolting technology redesigned from the ground up with expanded functionality, greater durability, and intuitive usability. This lightweight 36 Volt battery powered tool, with capacity up to 5,000 ft-lbs, is the ultimate solution for strength and portability in industrial bolting jobs worldwide. This tool is compatible with conventional sockets, the HYTORC Washer, and the HYTORC Nut.

EXPANDED FUNCTIONALITY



The LITHIUM SERIES II Tool incorporates TorcSense™ Technology which directly measures torque providing more repeatable results. Now available in a 5000 ft-lbs configuration expanding the operational capability of this tool. With all new features such as the sliding directional switch, snug function, user access levels, advanced bolting, and more further extends the versatility of the tool.

GREATER DURABILITY



The nickel plated all-aluminum housing greatly improves corrosion resistance and overall durability. The all new 36V brushless motor has more than 5 times longer life than its predecessor. Gearboxes are redesigned for 20% greater strength and reliability. The integrated rear cover shock guard absorbs impact protecting the display and buttons. Hall Effect trigger and directional switches increases dependability.

INTUITIVE USABILITY



The user interface and menu structure is remodeled for ease of use while presented on a high resolution display. Settings menu offers finer control of user preferences. Expansion of job data management provides flexibility in verifying work performed. Now standard with Bluetooth wireless technology makes data acquisition and firmware upgrades easier than ever. The work light and side handle further enhance safety and productivity.

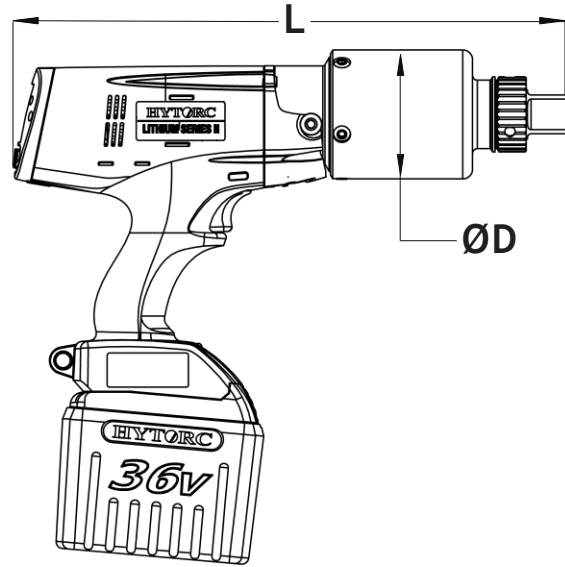
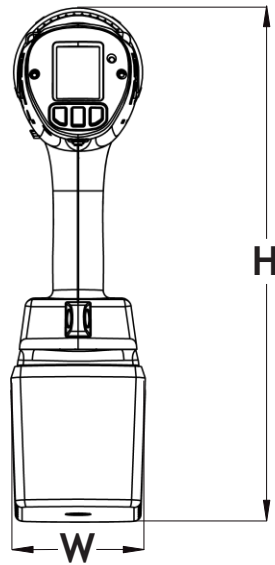

LEGEND: H = HEIGHT W = WIDTH L = LENGTH ØD = DIAMETER

CONFIGURATIONS	H	W	L	D	DRIVE	WEIGHT W/ BATTERY	SNUG	TORQUE		RUNDOWN
IMPERIAL	in.					lbs.	ft-lbs (Min)	ft-lbs (Min)	ft-lbs (Max)	RPM
LST-0700	129	3.5	114	2.6	0.75	117	35	150	700	61
LST-1200	129	3.5	117	2.6	0.75	120	60	200	1,200	40
LST-2000	132	3.5	139	3.2	1.00	166	100	325	2,000	17
LST-3000	133	3.5	144	3.4	1.00	177	150	500	3,000	11
LST-5000	166	4.0	154	4.0	1.50	224	200	800	5,000	7
METRIC	mm					kg	Nm (Min)	Nm (Min)	Nm (Max)	RPM
LST-0700	328	89	290	66	19	5.3	47	203	949	61
LST-1200	328	89	297	66	19	5.5	81	271	1,627	40
LST-2000	335	89	353	81	25	7.5	135	441	2,712	17
LST-3000	338	89	366	86	25	8.0	203	678	4,067	11
LST-5000	422	102	391	102	38	102	270	1,085	6,779	7

COMPLETE KIT CONTENTS

- LITHIUM SERIES II Tool
- Reaction Arm
- Storage Case
- 36V Battery (Two)
- Battery Charging System
- Side Handle
- Calibration Certificate
- Operation Manual

LST

Model:
LITHIUM SERIES TOOL

Capacity:
Available: 0700, 1200,
2000, 3000, 5000

Communication:
Blank: Bluetooth Communication
U: USB Only

Examples:

1. LST-0700 standard tool, 700 ft-lb capacity, with Bluetooth Communication
2. LST-0700-U standard tool, 700 ft-lb capacity, without Bluetooth – USB Connection Only



Address:

PH Ofidepositos Tocumen, Bodega
#10 Via Panamericana, Mañanitas.
Ciudad de Panamá, Panamá

Phone:

507 382-8015

Email:

info@toolsolutionscorp.com

Online:

toolsolutionscorp.com