

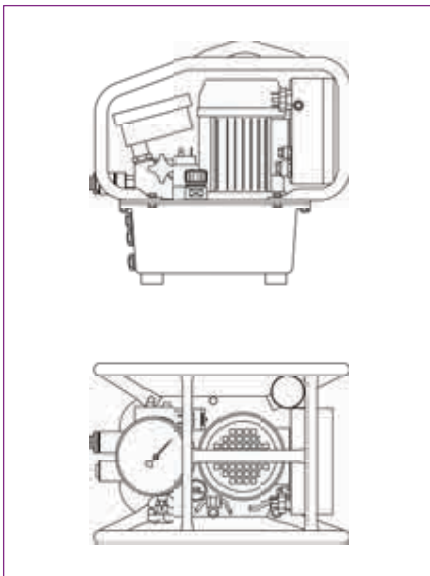

## JETPRO S

The JETPRO S 2-stage Hydraulic Power System is the most affordable lightweight pump on the market. The JETPRO's compact design and one-gallon reservoir alleviates weight restrictions like no other hydraulic pump which offers the operator efficient mobility. Simple two-button controls ensure the operator's ease of use while also speeding up the bolting process. The JETPRO operates at a very quiet ~80 dB.



### PUMP SPECIFICATIONS AND FEATURES

Power	115v (75 Amp) / 230v (4.5 Amp)
Gauge	0-10 k PSI (+/-1% Accuracy)
Reservoir Capacity	0.8 gals. / 3.0 l
Stages	2
Weight	33 lbs. / 15 kg
Maximum Oil Flow Rate	310 cu. in./min. / 5 l/min.
Oil Cooler	No
Protective Caging	Yes
15' Remote Control	Yes

#### Address:

PH Ofidepositos Tocumen, Bodega  
#10 Via Panamericana, Mañanitas.  
Ciudad de Panamá, Panamá

#### Phone:

507 382-8015



**TOOL**  
**SOLUTIONS**  
Hidráulico - Eléctrico - Neumático

#### Email:

info@toolsolutionscorp.com

#### Online:

toolsolutionscorp.com